

IJPGC2002-26154

## ALSTOM POWER'S FLASH DRYER ABSORBER FOR FLUE GAS DESULFURIZATION

Stefan Ahman,  
Environmental Systems Division  
ALSTOM Power, Inc.

Charles B. Barranger,  
Environmental Systems Division  
ALSTOM Power, Inc.

Peter G. Maurin  
Environmental Systems Division  
ALSTOM Power, Inc.

### ABSTRACT

ALSTOM's Flash Dryer Absorber (FDA) system is a dry FGD technology, which aims for simplicity and compactness. This first installation was in Poland at the 2x120 MWe Lasiska site, and was commissioned in 1996. Since then there have been a number of important developments of technology, notably combination with an ESP, use of integrated lime hydration and use of ash from CFB as the reagent; supported by an ongoing test program. The technology also looks promising for the retrofit area. The combined full-scale plant for the removal of flyash and SO<sub>2</sub> can often be fitted into the space occupied by the existing electrostatic precipitators. There are seventeen commercial installations of FDA in various stages of operation, construction, and design.

### INTRODUCTION - OPERATING PRINCIPLE OF THE FDA DFGD PROCESS

As displayed in Fig. 1, fly ash from the boiler is filtered from the flue gas in a Fabric Filter (FF) and reintroduced back into the FF inlet duct through a re-injection mixer and FDA reactor. Hydrated lime (Ca(OH)<sub>2</sub>) is added to the system via a hydration unit attached to the mixer. The hydrated lime overflows to the FDA mixer and water is added to the mix. The humidified mix is injected into the FDA reactor and cools the FDA inlet flue gas temperature by evaporating the water added onto the dry flue ash particles. The process is designed to cool flue gas to the optimum level required for efficient collection of the acidic SO<sub>2</sub> components. The cooled flue gas then flows to the dust collector, a FF or and Electrostatic Precipitator (ESP), where the particles in the flue gas are removed and recycled back through the FDA process. Clean gases from the fabric filter are transported to a stack by means of induced draft fan. To minimize plugging, or maldistribution of the lime, fly ash,

and water, the products are blended within the reactor. This process provides the appropriate conditions for the required SO<sub>2</sub> removal efficiency. A FF hopper level controls the quantity of end products delivered to the end product silo.

The FDA system is based on the ability to recycle very high amounts of dry solids. This allows for keeping the ratio water/recycled low and thus safe against over wetting the recycle. The recycle ash remains free flowing material even after wetting in the mixer. The amount of absorbent, which is recycled, is much greater than in a conventional dry FGD process. Thus, the time for drying of the recycle ash added to the flue gas is very short, which in turn makes it possible to use small reactor vessels. In fact the volume is an order of magnitude less than the corresponding size for a conventional dry flue gas cleaning system based on spray dryer technology.

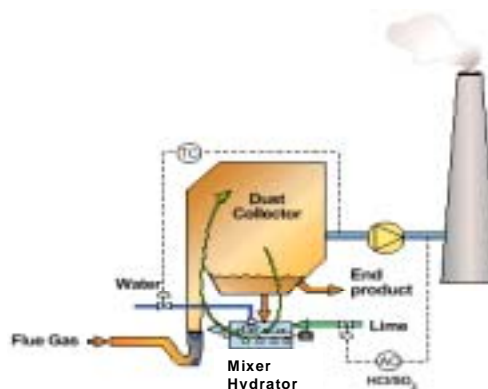

Figure 1  
Flash Dryer Absorber System

## MIXER

The mixer is of ALSTOM's proprietary design. See Figure 2. It is designed to work in concert with the FDA reactor. The mixer is bolted onto the reactor walls. Thus wetted ash has a very short distance to be transported before it is dispersed into the flue gas. The recycled ash flows into the mixer through a rotary valve, placed above the mixer. The rotary valve is almost as wide as the mixer to achieve an even flow of recycle ash over the entire cross section of the mixer and thus likewise an even distribution into the reactor. Low pressure nozzles are used to spray water onto the recycle ash. The mixer has two parallel shafts which are arranged parallel to the reactor wall. The mixing elements are arranged on these shafts.

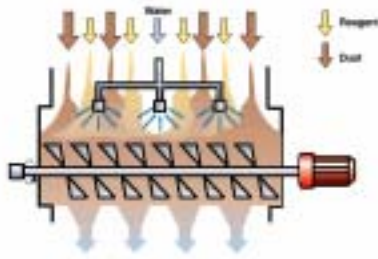

Figure 2  
FDA Mixer

This arrangement which is based on a rectangular geometry of the reactor and its mixer is very important since it allows for easy scale up and standardization of the equipment. Based on this concept a series of standard size reactor and mixer modules has been developed.

## INTEGRATED LIME HYDRATION

An important additional feature is the integrated lime hydrator, which likewise is a standardized equipment module. The cost of dry hydrated lime is higher than for lime. Roughly speaking a ton of lime costs as much as a ton of dry hydrated lime. Expressed as a cost per the active calcium part, this means an extra cost for the dry hydrated lime of some 30%. Moreover, the bulk density of the two products are very different; lime is typically 900 to 1200 kg/m<sup>3</sup>, whereas dry hydrated lime is only 450 to 640 kg/m<sup>3</sup>. These factors no doubt make lime the preferred product from a transportation point of view; moreover, much less silo capacity is required for lime.

The simplest way of utilizing quick lime rather than dry hydrated lime is to feed the quick lime, CaO, directly to the process. Experience has shown, though, that this mode of operation often leads to a reduced utilization of the alkalinity of the reagent. The reason for this is not quite clear, but it is assumed that all of the lime may not be readily reacted, due to the local excess of heat generated as the lime hydrates.

The hydration reaction is seemingly simple:

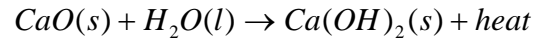

The reaction is highly exothermic, 15.2 kcal/mol or 318 kWh/ton CaO. This heat of reaction is leaving the hydration vessel as water vapour; a higher than stoichiometric amount of water is thus added for the hydration, or about 0.5 – 0.6 kg H<sub>2</sub>O/kg CaO.

Conventional dry lime hydrators typically operate at a fixed load with a minimum of controls. This is rather logical, since there is a silo to fill up; until the maximum level is reached, there is hardly any reason to change the parameters for the hydration. The key parameter to keep track of is the residual moisture in the hydrated lime; the lime must not get too moist, to avoid problems when handled and stored. Because of this, conventional hydrators are operated at around 100 deg C, since the dry hydrated lime will be stored in a silo.

To overcome these shortcomings of the conventional lime hydrators, the FDA Integrated Lime Hydrator Mixer was developed. The concept is shown in Fig. 3 and Fig 4.

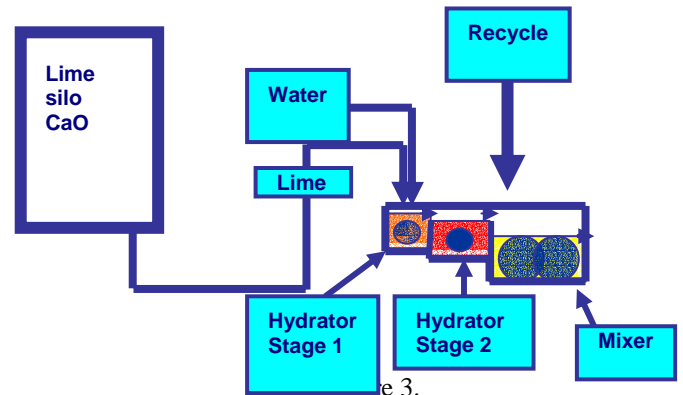

Figure 3.  
FDA Integrated Lime Hydrator/Mixer Flow Schematic

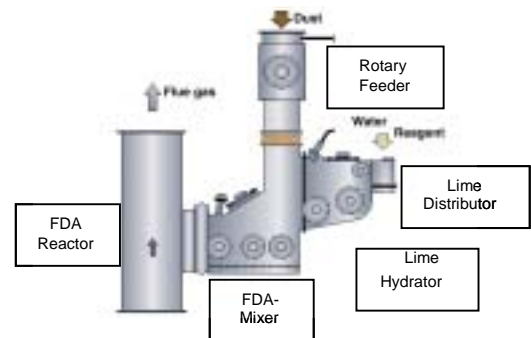

Figure 4.  
Equipment Arrangement

Lime and water are fed into the hydrator, which comprises two stages; in the first stage water and lime are mixed together. In this stage the “induction period” of the hydration reaction takes place. This period normally lasts only 1 – 2 minutes; until the heat evolving reaction starts.

From the first stage, the wetted lime overflows into the second stage, where the material undergoes a drastic physical transformation; the somewhat lumpy material from the first stage literally falls apart into a very fine powdery material: the hydrated lime. The second stage has a larger volume than the first one and it is designed with respect to the reactivity of the lime quality to be used for a particular situation.

The design of the Integrated Hydrator/Mixer is open and the flow direction is perpendicular to the mixer shafts of the respective stages. The lime is fed to an intake box from where it overflows by gravity into the hydrator, passes its two stages, to finally overflow into the FDA mixer.

The unique design of the hydrator allows free passage of material from inlet to outlet; the design also prevents excessive mechanical stresses on the equipment as a consequence of the flow direction. Due to this, the hydrator can be operated at lower temperatures than conventional dry hydrators can, which in turn allows for the production of a hydrated lime with a very high surface area. Test results show that hydrated lime of a BET surface in excess of 30 m<sup>2</sup>/g can be produced, a value to be compared with that of commercial dry hydrated lime, which is limited to a BET surface area of 15 – 17 m<sup>2</sup>/g.

The feed of lime is determined on an “as needed” basis; i. e. the feeds of lime and water into the hydrator are controlled to match the quantity asked for by the FDA control system.

## PARTICULATE COLLECTOR

The FDA system can use either a fabric filter (FF) or an electrostatic precipitator (ESP) as a dust collector. In most cases FFs were selected for the following reasons:

(i) less footprint is required for a FF compared to an ESP ; the size of the FF is relatively independent of the dust emission requirements, while the size of the ESP grows considerably when very low dust emissions are required.

(ii)less costly; the cost of installation is less for the FF, while the cost of operating a fabric filter is comparable to that of operating an ESP – the pressure drop of the FF is to be compared with the power used by the transformer rectifiers of the ESP.

(iii)higher utilization of the reagent; an important feature of the FF is that some additional absorption of SO<sub>2</sub> takes place in the dust filter cake formed on the bags, thus somewhat less reagent is used if a FF is used.

For future installations the FF is believed to become the preferred collector due to its proven ability to cope with fine particulate emissions. The operation of an ESP after a FDA system is relatively easy, since the high humidity of the flue gas effects the dust collection favourably due to a much reduced dust resistivity. For special cases, e. g. retrofit installations, the ESP may still remain a strong candidate.

## PARTICULATE COLLECTOR – FABRIC FILTER

A fabric filter located down-stream of the reactor collects the recycled product formed during the absorption process as well as the fly ash present in the flue gas. The fabric filter, shown in Fig. 5, has a central inlet plenum. The design is widely for industrial applications and coal-fired utility boilers. The design is characterized by:

Heavy industrial design for reliability and durability  
Filter maintenance from the clean side of the unit  
Effective intermediate pressure pulse air system for on-line cleaning

- Lowest First Cost
- Woven and Felted Fabrics
- Outside Collection
- On/Off-Line Cleaning
- Pulse (Medium & High)
- Panel Design
- Modular Design
- 3.0-4.0 FPM Filter Speed

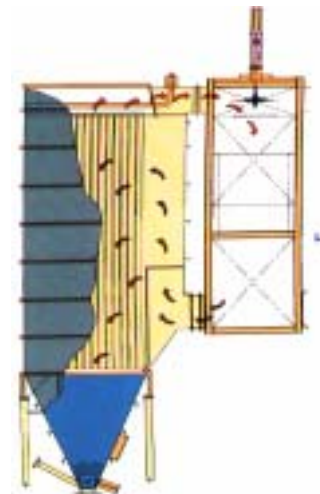

Figure 5.  
Fabric Filter

The filter has proven its capability of achieving low dust emissions in a multitude of applications. With the injection of absorbents excellent control of gaseous components have also been established.

The casing is a welded negative pressure design, adequately stiffened to avoid fatigue failures through the life of the unit. The support structure is designed to absorb thermal expansions for all size units. Care has been taken in designing the plant to avoid cold bridges. The casing is designed with reinforced steel members on the outside of the box and thermal insulation is installed over these members to ensure an efficient thermal insulation system. For low heat loss, double top access covers are supplied.

The fabric filter hoppers are used to capture the filtered product and recycle it to the mixers. Adequate valley angles, surface heat, thermal insulation, and fluidising air ensures trouble-free flow of recycle product.

To avoid local hot or cold spots, hopper surface heat is maintained through a double wall construction that utilizes heated air for surface heat temperature distribution. Thermal insulation and lagging resist the lose of the heated surface.

The pulsing system includes a unique patented pulse valve integrated into the manifold for maximum efficiency. The use of intermediate pres-sure also reduces the risk of condensation with moist gases. The membrane and pilot valve have been especially developed for this particular application to ensure reliability in performance. These valves have been endurance tested under relevant conditions to ensure plant availability. The pulse distribution (nozzle) pipes are designed to give an even distribution of cleaning power to each bag. A rigid support system guarantees the correct position of the pipe on re-assembly.

The filter bag is a crucial element in providing reliable high quality performance. The design uses the "snap strap" design. Twenty years of experience offers great confidence in this design. The bag design includes a bumper ring at the bottom to avoid bag failures from bags occasionally colliding. The support cage is a rigid design to provide adequate support for the filter bag during all conditions. Quality control procedures address the welding quality to avoid bag failures from loose wires. Care has been exercised in designing the cage for easy removal, which can be made without the need of tools. Critical design areas have been identified as the bag bottom and support rings. These items have been designed to avoid folding of the bag over the cage.

## PARTICULATE COLLECTOR-ELECTROSTATIC PRECIPITATOR

Normally a fabric filter is used with FDA, but in some cases an electrostatic precipitator (ESP) may be the preferred dust collector. This combination has been subject to an R&D effort, including aerodynamic model studies, as well as, testing in a pilot plant.

Testing reveals that the SO<sub>2</sub> removal efficiency drops a few percentage points, but the combination may still be of particular interest, especially when it comes to retrofit situations, where an existing ESP may be re-used. Extra collecting surface may be needed in come cases, but the resistivity of the dust is drastically reduced during FDA operation, so an existing ESP may do surprisingly well if FDA is installed.

In case of an ESP, the FDA installation has to be configured somewhat differently from that for a fabric filter. The reactor is made an integral part of the ESP inlet nozzle see

Fig. 6. This means that recycle ash is transported back to the inlet side of the ESP, and that the ash then passes through the mixer before being dispersed in the reactor duct.

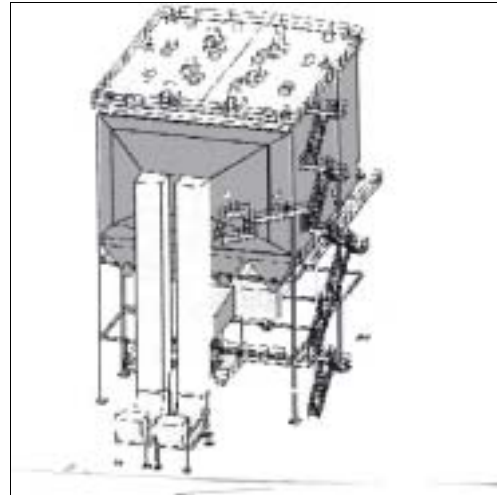

Figure 6.  
FDA with Electrostatic Precipitator

Such an ESP-FDA combination has been installed at a new 280 MWs coal fired boiler in Quzhou, Zhejiang province, China, with operation due later this year. The gas flow is 300,400 nm<sup>3</sup>/h and the expected sulfur removal is 85 percent.

## APPLICATIONS

The FDA has so far been applied for a variety of applications; coal power boilers, diesel exhausts, boilers burning municipal waste and biofuel.

For applications with high hydrogen chloride (HCl) contents, the system is ran at higher outlet temperatures. This is a consequence of the hygroscopicity of the calcium chloride that is formed as the reaction product between the acid and the lime. In spite of this the removal of HCl is in the 95 – 99+ % range. Hydrogen fluoride (HF) is likewise removed at + 95 %. The system also catches aerosols such as acid mist of sulfur trioxide (SO<sub>3</sub>). The passage of the gas through the alkaline "filter aid" on the FF bags constitutes a very efficient trap for submicron particles.

The efficient filtration paired with the cooling further means that heavy metals (including condensables) are removed very efficiently. Depending on the actual form of mercury, this species is also removed. For enhanced removal of mercury and dioxins, activated carbon may be added to the system. The stringent requirements of the German BIMSch and the EU norms are easily fulfilled.

## CFB FDA APPLICATIONS

Alkaline ashes can be used as the additive for FGD systems. This is potentially a very interesting approach to lower the operational costs of desulfurisation. Ashes may be alkaline as a result of the actual composition of the ash of the coal. The ash may also have a high level of alkalinity, for example, as a result of limestone injection into the boiler.

In the boiler the limestone is subject to two parallel reactions: calcinations and sulphation. Generally, one would expect a material like an ash from a circulating fluidized bed (CFB) boiler to be rather inactive for a post combustion process.

The sulphation reaction is thought to limit the utilization of the reagent by blocking the pores of the calcined limestone with a surface layer of calcium sulphate. In the boiler the aim is to utilize the limestone to its maximum; thus yielding an ash of a high sulphate content.

CFB boilers are often operated around 850°C. This combustion temperature more or less coincides with the optimum temperature for the sulphation reaction of the limestone. Since a CFB ash is a highly sulphated material it would then have an inactive surface layer when reacted in a post combustion process.

These preconditions would seem to argue against the use of CFB ash as a reagent in a FGD system based on lime. Pilot tests indicate, however, that it is indeed possible to use the CFB ash for further absorption of SO<sub>2</sub> in a FDA system.

Combining a FDA system and a CFB boiler is particularly interesting for high removal efficiencies, especially when firing high sulfur fuels.

By shifting some of the sulfur removal to the FDA system, the limestone flow to the CFB boiler can be reduced. The potential reduction is greater as the demand on the total removal rate is increased. Studies indicate that the limestone flow in some cases could be reduced by as much as 30 percent; if the total required sulfur reduction exceeds 97 percent, it may well be possible to reduce the limestone feed to the CFB even further.

The advantages of combining the CFB and a FDA system are considerable. Over 95 percent combined sulfur removal can be realized even for high sulfur fuels, at the same time reducing limestone consumption. Since less limestone is used, the quantity of ash to be disposed of is likewise reduced. The CFB boiler efficiency is also increased, since the endothermic decomposition reaction of the limestone to form lime is reduced by the reduced limestone feed.

## DFGD FDA CONCEPT FOR FOSSIL FUEL CFB APPLICATION

This Dry Flue Gas Desulfurization (DFDG) process equipment was developed to reduce the SO<sub>2</sub> and Particulate emission levels released to the atmosphere by burning solid fuel in a Circulating Fluidbed Combustor (CFB), Fig. 7 & Fig. 8. This is accomplished by treating the CFB fly ash with water, and re-injecting the mixture back into the flue gas stream. As the limestone/fuel mixtures are combusted in the CFB, CaO is calcined in the CFB and ejected with the fly ash to the FDA plant. This CaO reacts with, and removes the SO<sub>2</sub> from the flue gas. The Particulates are filtered from the flue gas in a Fabric Filter. A separate lime injection system normally included with DFDG plants is not required and not included in the FDA process. The FDA will allow the CFB to operate at lower limestone consumptions or at higher SO<sub>2</sub> removal efficiencies.

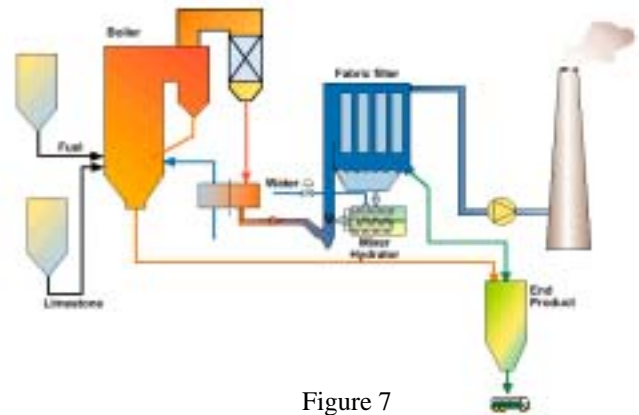

Figure 7  
FDA for Circulating Fluid Bed

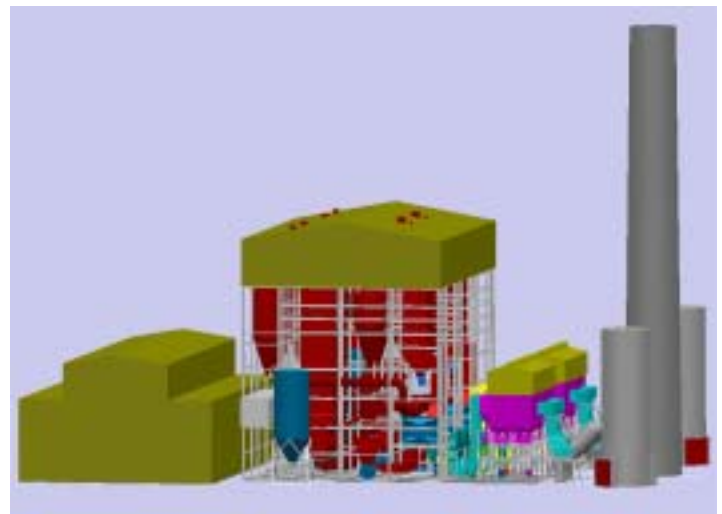

Figure 8  
FDA for Circulating Fluid Bed 3D

## BY PRODUCT UTILIZATION

While for the wet FGD process there already existed a market demand for gypsum and the FGD by-product could gradually replace the use of natural gypsum, the establishment of recycling and utilization for the new dry FGD product has been more difficult. However, now 10-15 years after the more general introduction of dry FGD different options for and experiences from large-scale utilization schemes have been developed, especially in Europe. As much as 91 percent of the production of dry FGD product is registered as going into utilization areas within the European Union (ECOBA statistics for 1999).

It is encouraging to be able to communicate that indeed a number of large-scale options for utilization of dry FGD product have been realized. Besides landfill disposal there are now different possibilities for "market disposal", resulting in an utilization of dry FGD product within EU of 86% for the year 1998. This development has been realized thanks to and due to; a number of extensive research and development projects, a general high ambition in industry aiming for utilization. In a few countries increasing landfill taxes has also driven this development.

To summarize the most important utilization possibilities today: The Nordic countries, Sweden, Finland and Denmark, have more than ten years experience of commercial applications of dry FGD/fly ash mixtures as fill and sub-base material for storage areas, parking lots, embankment material for roads, sealing layers, etc. An initiative has been taken to develop a standardization of dry FGD/fly ash mixtures for such civil engineering applications, by means of an EU-project under the coordination by VGB. Such an effort should further support the utilization of dry FGD product in this civil engineering area.

In a few countries, i.e. Germany and Poland, the utilization of dry FGD product as stowing material and mining mortar component for coal mines is quite extensive.

The market interest for dry FGD product as fertilizer will continue to increase after successful research in the 1990's. The product is now used in Denmark, Germany and Austria as a fertilizer. Germany is issuing a new lime fertilizer legislation defining the dry FGD product as a new S-Ca fertilizer.

The use of dry FGD product as reagent in wet FGD and conversion to gypsum is used commercially now on a large scale in Denmark. This solution can site specifically be of great interest, reliant upon close availability of a wet FGD plant with enough capacity as well as a local gypsum market demand.

Other discussed options, like thermal conversion to anhydrite for utilization as setting in cement, use as component in bricks and aggregates of different kind, etc. have been

demonstrated technically, but remains small-scale possibilities and are not proven viable on a large-scale.

## FDA DFGD ADVANTAGES

The FDA process has several advantages:

### Capital Investment Cost

Capital Investment Cost for a FDA system is low, primarily because of its inherent simplicity.

### Footprint

Integrating the reactor, absorbent preparation system and the particulate collector offers the minimum footprint possible. This is of particular interest in retrofit situations where space is typically very scarce.

### Operating costs

The high recirculation rate in the system facilitates an efficient utilization of the residual alkali in the CFB ash. Limestone consumption for given removal efficiency will be lowered.

### CaO Slaking

The water added to the mixer provides adequate slaking of the CaO in the ash for a highly efficient removal SO<sub>2</sub> in the flue gas. This eliminates the need for handling lime slurry and then spray drying producing a dry powder. FDA starts dry and stays dry. This drastically simplifies and reduces the operating cost for the system.

### Maintenance costs

The plant is designed to reduce corrosion and wear to a minimum. With a minimum of moving parts follows low cost of replacements or repair and lower manpower needed for maintenance.

### Scaling or corrosion

Because the gas cooling process is flash drying which is nearly instantaneous and the reaction product is dry inside the reactor, - there are no free water droplets, or wet/dry interface problems that promote clogging, build-up, scaling or corrosion (as with conventional DFGD processes).

### Materials of construction

As opposed to wet scrubber processes, each plant component in contact with the flue gas is dry at all times. All components are operated under alkaline conditions. (i.e. with pH-values of > 12).

The SO<sub>3</sub> and HCl content of the flue gas is absorbed preferentially and immediately on entering the FDA reactor. Therefore, the acid dew point is not reached in the downstream equipment of the absorber or in the stack.

### Flexibility

The system adjusts rapidly to variations in flue gas flow, temperature and composition (i.e. SO<sub>2</sub>, SO<sub>3</sub> and HCl content). The system lends itself ideally to automatic control and accommodates quick load changes.

### Reliability/Availability

The FDA plant has a very high reliability and availability, due to its uncomplicated simple design with no moving parts in the flue gas path, or the heavy-duty water injection system out of the gas stream and no free water in the flue gas.

### Waste water

The system creates no wastewater. The by-product is a dry powder with multiple possible uses including construction, fertilizing, linings, stabilization, and land filling.

### Process Water

The FDA system has the potential to utilize low quality water for the process and thus potentially reduces the water emissions from your plant. The water used is all evaporated.

### Product

The product is a dry, free-flowing powder, which lends itself to conventional handling and storage. When it contains a certain proportion of fly ash, it has pozzolanic properties, making it suitable for a variety of uses. Unlike the effluent from wet scrubbers, heavy metals are bound in an insoluble matrix in the "stabilization" or by-product of the process after moistening.

### Reheat of flue gases

The cleaned flue gas emerges at a temperature above saturation, is droplet-free and therefore suitable for direct discharge without risk of immediate condensation. However, should emission (i.e. atmospheric dispersion) considerations dictate heating to a somewhat higher temperature, this can be carried out in a simple straight-tube indirect steam heater. The absence of droplets eliminates surface corrosion risk.

## SUMMARY

The FDA technology offers a simple, low cost desulfurization system with high performance, minimum space requirements and easy access. The fact that the combined full-scale plant for the removal of fly ash and SO<sub>2</sub> can be fitted into the space of the existing electrostatic precipitators is of particular interest for further application of the FDA technology for retrofit situations. The combination of the FDA system with CFBs with limestone addition to the boiler offers an interesting opportunity for an optimum solution for the desulfurization of high sulfur fuels.

## REFERENCES

- Ahman S. and Gottschalk J. *Ein neues Trockensorptionsverfahren*, VGB Krfwerkstechnik 77 (1997).
- Ahman, S. and Wiktorsson, A. *Dry FGD System Recent Developments*, POWERGEN EUROPE, Helsinki, Finland, June 20-22, 2000.
- Bengtsson, S. *Semi-Dry FGD End Product Utilisation*, European Experiences-2000.